

# Aqua-Pure®

Spec # \_\_\_\_\_

Quantity \_\_\_\_\_

## Models:

**AP-R05500**

**Reverse Osmosis  
Drinking Water System**

### Applications:

- High Quality Water
- Sediment/Rust<sup>1</sup>
- Chlorine Taste & Odor
- Reduction of:  
Lead, Arsenic, TDS, Turbidity, Parasitic Protozoan Cysts, Radium, Barium, Cadmium, Chromium, Copper, Fluoride & Selenium

### At a Glance:

- Exclusive quick change filter cartridge
- Installation hardware and faucet included
- Manufactured from FDA CFR-21 compliant materials

### Product Benefits:

- Advanced four stage filtration process to help provide superior quality drinking water at less cost than bottled water
  1. Five micron sediment & rust filtration
  2. Activated carbon filtration
  3. Reverse osmosis membrane
  4. Final activated carbon polishing filtration
- Universal system design that may be used on chlorinated or non-chlorinated, municipal or well systems
- High flux, thin film composite RO membrane that helps provide high quality water production rate, at 25 gallons (95 liters)<sup>2</sup> per day
- Advanced automatic shut-off helps promote peak efficiency and water conservation
- Includes long reach faucet, 2.4 gallon (9 liter) tank and necessary water/ drain connections
- Exclusive sanitary quick change cartridge design to help provide fast easy cartridge change with minimal effort



**AP-R05500**

### Product Specifications:

Component	Inlet/Outlet Size	Dimensions (L x W x H)	Approx. Weight	Capacity	Min. TDS Reduction	Max. Influent TDS	Max. Water Temp.	Max. Water Pressure	Membrane Production <sup>1</sup>
RO Module Assembly	1/4" Inlet Tubing	14-5/8 x 5-5/8 x 14-1/8" (37.2 x 14.3 x 35.9 cm)	19 lbs. (8.6 kg)	N/A	95%	2,000 ppm	100°F (37.8°C)	125 psi (862 kPa)	25 gpd (95 lpd)
Storage Tank	3/8" Outlet Tubing	9-1/4 x 14-3/8" (23.5 x 36.5 cm)	6.8 lbs. (3.1 kg)	2.4 gal. w/60 psi feed (9.1 lit. w/414 kPa feed)	N/A	N/A			N/A

<sup>1</sup> These claims are not tested or certified by NSF

<sup>2</sup> Flow rates are based on RO Module capabilities. Actual daily production rates can vary by up to 50%.

# Aqua-Pure®

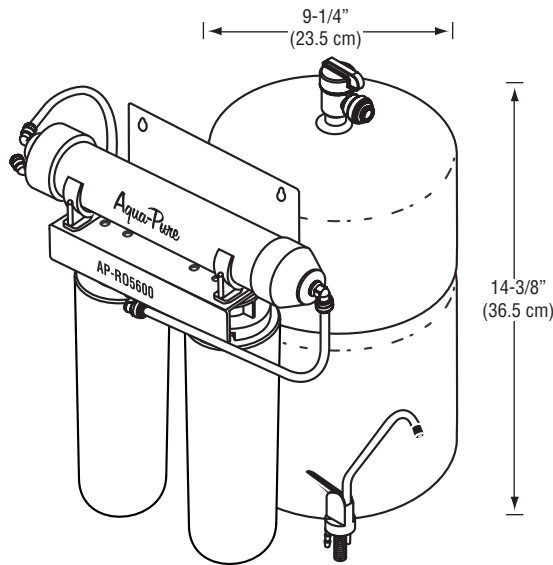

AP-RO5500

## Easy Installation:

**CAUTION:** Diagram shown is for reference purposes only. Read installation and operation manual prior to installing the unit.

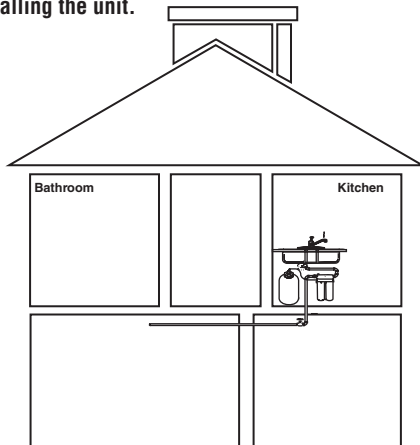

## Limited Warranty:

CUNO Incorporated warrants this Product to be free from defects in material and workmanship for one (1) year from the date of purchase. This warranty does not cover failures resulting from abuse, misuse, alteration or damage not caused by CUNO or failure to follow installation and use instructions. If the Product is defective CUNO will replace the Product or refund your Product purchase price. CUNO will not be liable for any indirect, special, incidental, or consequential damages arising from the use of this Product. Some states do not allow the exclusion or limitation of incidental or consequential damages, so the above limitation may not apply to you. To obtain warranty service, mail your request to Warranty Claims, CUNO Incorporated, 400 Research Parkway, Meriden, CT 06450. Proof of purchase (original sales receipt) must accompany the warranty claim, along with a complete description of the Product, model number and alleged defect. This warranty gives you specific legal rights and you may have other rights which vary from state to state, or country to country.

Distributed by:

CUNO and Aqua-Pure are trademarks of 3M Company used under license. NSF is a trademark of NSF International. © 2007 3M Company. All rights reserved. LITAP631 0206

Spec # \_\_\_\_\_

Quantity \_\_\_\_\_

Model Number \_\_\_\_\_

Part Number \_\_\_\_\_

## Physical Specifications:

- 1/4" Inlet Tubing
- 3/8" Outlet Tubing
- System is manufactured from FDA CFR-21 compliant materials
- System has a maximum operating pressure of 125 psi (862 kPa) and operating temperature of 100°F (37.8°C)
- System includes long reach faucet, 2.4 gallon (9 liter) tank and necessary water/drain connections
- System to be installed on primary kitchen cold water line

### Media Options

Model	Description	Change-Out Interval	Quantity
AP5527	1 Pre-Filter 1 Post-Filter	Once every six (6) months	2
APRM5500	RO Membrane	Once every three (3) years	1

**WARNING:** Do not use with water that is microbiologically unsafe or of unknown quality without adequate disinfection before or after the system. The contaminants or other substances removed or reduced by this water filter are not necessarily in all users water. Systems certified for cyst reduction may be used on disinfected water that may contain filterable cysts.

EPA Establishment Number 070595-CT-001

CUNO Incorporated recommends regularly scheduled maintenance and replacement of the filter cartridge(s) in order for the product to perform as advertised/sold. **Change the filter cartridge at least every 6 months. Improper installation and maintenance may result in property damage due to water leakage.**



Visit [www.nsf.org](http://www.nsf.org) for the claims associated with products that are NSF listed.



**CUNO Incorporated**  
400 Research Parkway  
Meriden, CT 06450 U.S.A.  
Toll Free: 1.800.222.7880  
Worldwide: 203.237.5541  
Fax: 203.238.8701  
[www.aquapure.com](http://www.aquapure.com) • [www.cuno.com](http://www.cuno.com)